

HOT-637
Pentium™ II processor
Based AGP MAIN BOARD
User's Manual

FCC Notice:

This equipment has been tested and found to comply with the limits for a Class B digital device, pursuant to Part 15 of FCC Rules. These limits are designed to provide reasonable protection against harmful interference in a residential installation. This equipment generates, uses and can radiate radio frequency energy. If not installed and used properly, in strict accordance with the manufacturer's instructions, may cause harmful interference to radio communications. However, there is no guarantee that interference will not occur in a particular installation. If this equipment does cause interference to radio or television reception, which can be determined by turning the equipment off and on, the user is encouraged to try to correct the interference by one or more of the following measures :

Reorient or relocate the receiving antenna.

Increase the separation between the equipment and receiver.

Connect the equipment into an outlet on a circuit different from that to which the receiver is connected.

Consult the dealer or an experienced radio/television technician for help and for additional suggestions.

The user may find the following booklet prepared by the Federal Communications Commission helpful "How to Identify and Resolve Radio-TV Interference Problems." This booklet is available from the U.S. Government Printing Office, Washington, DC 20402, Stock 004-000-00345-4

FCC Warning

The user is cautioned that changes or modifications not expressly approved by the manufacturer could void the user's authority to operate this equipment.

Note : In order for an installation of this product to maintain compliance with the limits for a Class B device, shielded cables and power cord must be used.

CE Notice:

Following standards were applied to this product, in order to achieve compliance with the electromagnetic compatibility :

- Immunity in accordance with EN 50082-1: 1992
- Emissions in accordance with EN 55022: 1987 Class B.

NOTICE

Copyright 1997.

All Right Reserved

Manual Ver 1.0

All information, documentation, and specifications contained in this manual are subject to change without prior notification by the manufacturer.

The author assumes no responsibility for any errors or omissions which may appear in this document nor does it make a commitment to update the information contained herein.

TRADEMARKS

intel is a registered trademark of Intel Corporation

Pentium™ II Processor is a registered trademark of Intel Corporation

PC/AT is a registered trademark of International Business Machine Corporation.

PS/2 is a registered trademark of IBM Corporation.

All other brand and product names referred to in this manual are trademarks or registered trademarks of their respective holders.

T

TABLE OF CONTENTS

PREFACE	3
CHAPTER 1 INTRODUCTION	4
Specification	4
Accessories of HOT-637	6
CHAPTER 2 HARDWARE CONFIGURATION	7
The Pentium II Processor	7
What does the RM (Retention Mechanism) consist of	8
Install the Retention Mechanism and Heat Sink Support	9
Install Pentium II Processor	11
Jumpers.....	12
CPU Clock Speed Selection - JP35 and JP37	12
Clear CMOS - J19	14
Jumper for Seagate 5V IDE H.D.D - JP32	14
Flash EEPROM Vpp - J17	14
Connectors & Sockets	15
CHAPTER 3 MEMORY CONFIGURATION	17
CHAPTER 4 FLASH UTILITY	18
CHAPTER 5 AWARD BIOS SETUP	20
The Main Menu	21
Standard CMOS Setup	23
BIOS Features Setup	25
Chipset Features Setup	28
Power Management Setup	31
PCI Configuration Setup	34
Integrated Peripherals	36
Password Setting	39

P

PREFACE

HOT-637 mainboard is a highly integrated IBM PC/AT compatible system board. The design will accept Intel Pentium II processors which features high-performance pipelined burst secondary cache memory support with size of 512KB or 256KB. The memory subsystem is designed to support up to 512MB of EDO RAM and SDRAM in standard 168-pin DIMM socket.

HOT-637 provides a new level of I/O integration. Intel's 82440LX AGPset chipset provides increased integration and improved performance over other chipset designs.

HOT-637 main board provides an AGP slot to support a new generation of graphics cards with ultra-high memory bandwidth.

The 82440LX AGPset chipset provides an integrated Bus Mastering IDE controller with two high performance IDE interfaces for up to four IDE devices.

The onboard Giga I/O controller provides the standard PC I/O functions: floppy interface, two FIFO serial ports, an IrDA device port and a SPP/EPP/ECP capable parallel port.

Up to four PCI local bus slots provide a high bandwidth data path for data-movement intensive functions such as graphics, and up to three ISA slots complete the I/O function.

The HOT-637 provides the foundation for cost effective, high performance, highly expandable platforms, which deliver the latest in Pentium processor and I/O standard.

1 SPECIFICATION

The HOT-637 Mainboard is carefully designed for the demanding PC user who wants high performance and many intelligent features in a compact package:

Intel Chipset:

Features Intel's 440LX AGPset with I/O subsystems.

CPU Support:

Intel Pentium® II processor 233 ~ 333 MHz.

Versatile Memory Supports:

Equipped with **four DIMM sockets** support 168-pin 3.3V SDRAM and EDO DRAM memory modules, total memory size up to 512MB.

Configurable support for ECC (Error Checking and Correcting)

PCI and ISA Expansion Slots:

Provides four 32-bit PCI slots and three 16-bit ISA slots.

AGP Slot:

Supports Accelerated Graphics Port cards for high performance, component level interconnect targeted at 3D graphical display applications.

Onboard GiGA-I/O:

Provides one Floppy port; one optional PS/2 mouse connector; two high-speed UART compatible serial ports and one parallel port with ECP and EPP capabilities. Serial Port 2 can also be directed from COM2 to the Infrared Module for wireless connections.

Onboard PCI Bus Master IDE Controller:

Two **Ultra DMA/33 Bus Master IDE** Ports supports four IDE devices up to 33 MB/sec IDE transfers and supports Enhanced PIO Modes 3 and 4 and Bus Master IDE DMA Mode 2 devices.

Onboard 20-pin ATX Power Supply:

Provides ATX power connector onboard supports soft-on/off function.

System BIOS:

Provides licensed Award V4.51PG BIOS on Flash EEPROM.
Supports Green PC, DMI and Bundled with NCR SCSI BIOS.

ACPI:

Support **ACPI (Advanced Configuration and Power Interface)** function. ACPI provide more Energy Saving Features for the future operating system supporting OS Direct Power Management (OSPM) functionality.

Board Size:

ATX form factor 305mm x 170mm.

Advanced Features:

Low EMI -- Spread Spectrum built in - $\pm 1.5\%$ modulation and automatic clock shut-off of unused PCI/SDRAMS slots to reduce the EMI.

Dual Function Power Button -- The system can be one of two states, one is Suspend mode and the other is the Soft-off mode. Pushing the power button for less than 4 seconds will place the system into Suspend mode. When push the power button for more than 4 seconds, the system enters the Soft-off mode.

Modem Ring Power-on -- The system will power-on automatically by activating of modem ring.

More Advanced Features (option):

Voltages Monitoring -- System voltages levels are monitored to ensure stable current to main board components.

System voltages include V_{CORE} and V_{L2} for CPU, and +5V, +12V, -5V, -12V for system.

FAN Status Monitoring -- To prevent CPU overheat, CPU fan is monitored for RPM and failure. (CPU Cooling FAN with RPM sensor is required)

ACCESSORIES OF HOT-637

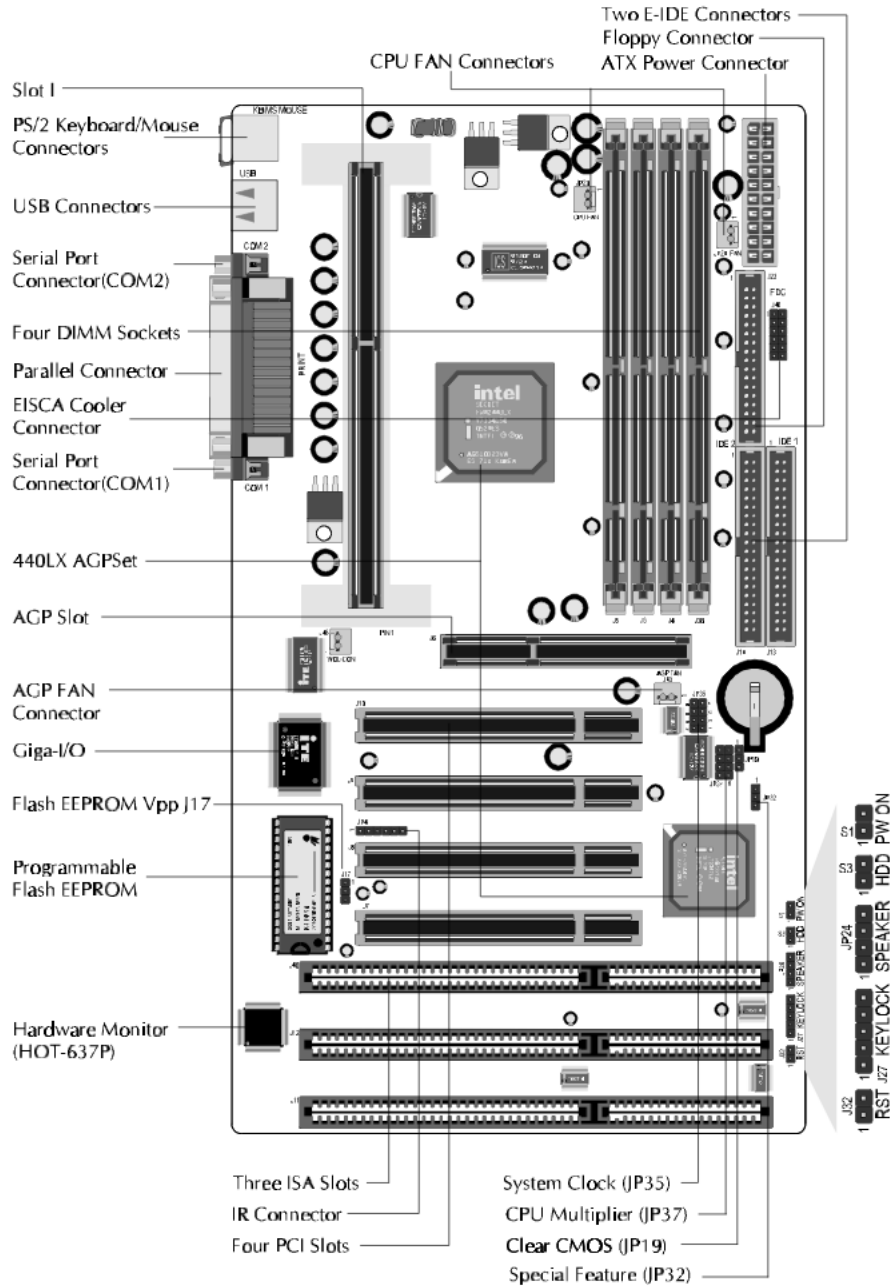

2 HARDWARE CONFIGURATION

The Pentium II Processor

The Pentium II processor is the next member of the P6 processor family. It combines the architectural advances in the Pentium Pro processor with the instruction set extensions of MMX technology. It is fully compatible with the huge base of Intel architecture-based PC software. Additional, the Pentium II processor delivers new levels of performance for advance media and communications software including powerful, realistic graphics and imaging capabilities, video conference, and the ability to run full-screen, full-motion video. The combination of these advanced technologies makes the Pentium II processor the ideal choice for executing modern 32-bit compute-intensive and multimedia-enhanced application workloads using advanced 32-bit operating systems.

The Pentium II processor has a separate, 32KB, on-chip, non-blocking L1 cache which runs at the processor frequency and a 512KB or 256KB on-board L2 non-blocking cache runs at half the processor speed.

The Pentium II processor using Single Edge Contact (S.E.C.) cartridge packaging technology which enables high volume availability, improved handling protection.

Recently release will feature Pentium II processors running at 233, 266, 300 and 333 Mhz.

Figure 2-0 show the front, rear and top views of Pentium II processor (without heat sink mounted).

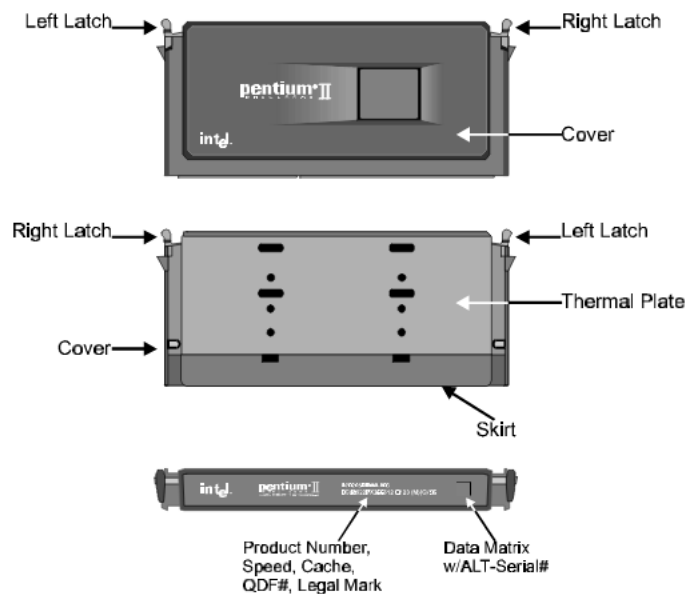

Figure 2-0

What does the RM (Retention Mechanism) consist of

Pentium II processor requires the Retention Mechanism (RM) and the Heat Sink Support to hold the base processor in the S.E.C. cartridge.

Following installation procedure will display how to install these mechanism. Please consult to your supplier for the mechanism.

Retention Mechanism package consists of 2 separate parts and the Heat Sink Support consists of 3 separate parts.

- Retention Mechanism (RM) - Plastic Guide with captive nuts that hold the S.E.C. Cartridge in the Slot1 connector. (Refer to Figure 2-1-1)

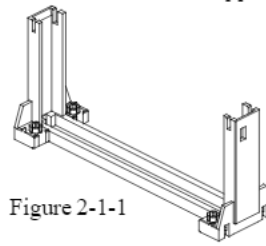

Figure 2-1-1

- RM Attach Mount (RMAM) - Bolt/Bridge assemblies inserted up through the bottom of the mainboard. Then secures the RM to RMAM (two RMAM required per RM). (Refer to Figure 2-1-2)



Figure 2-1-2

- Heat Sink Support Base (HSSBASE) - Plastic support bar mounted to the mainboard under the ATX heat sink. (Refer to Figure 2-1-3)

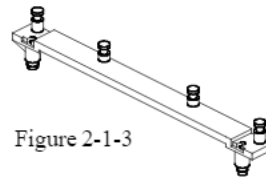

Figure 2-1-3

- HSS Pin (HSSPIN) - Plastic pins inserted through the HSSBASE to secure it to the mainboard (two required per Assembly). (Refer to Figure 2-1-4)

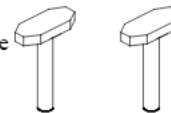

Figure 2-1-4

- HSS Top Bar (HSSTOP) - Plastic bar that clips onto the HSSBASE through the fins on the ATX heat sink. (Refer to Figure 2-1-5)

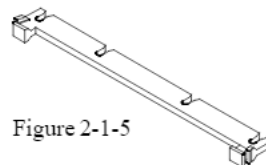

Figure 2-1-5

Install the Retention Mechanism and Heat Sink Support

Place the mainboard on a workbench (not in a chassis). Be sure that the mainboard is bare (that is, no SIMMs, cables, or cards are installed).

Install the Retention Mechanism :

1. Finds out the Retention Mechanism (RM) Mounting Holes and "Pin 1" mark of Slot 1 on HOT-637 main board. (Refer to Figure 2-2)

2. Install two Retention Mechanism Attach Mounts (RMAM) with Bolt/Bridge assemblies inserted up through the bottom of the mainboard. (Notice the RMAM's bridge orientation as Figure 2-3)

3. Insert the Retention Mechanism (RM) around the Slot 1. Be sure the Square Cut Mark of RM (Refer to Figure 2-4) have the same orientation of Slot 1 pin 1. (Refer to Figure 2-3)

4. Screw the four captive nuts (Refer to Figure 2-4) on the RM by a screw drive to secure RM to two RMAMs.

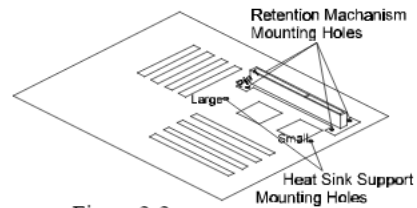

Figure 2-2

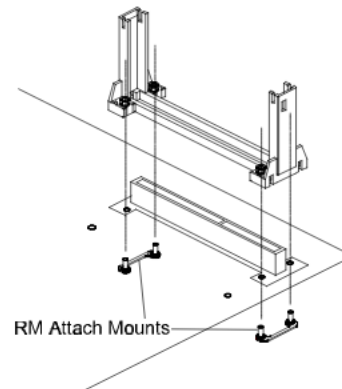

Figure 2-3

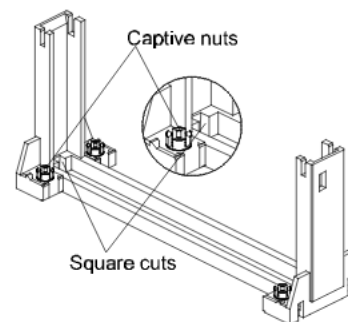

Figure 2-4

Install the Heat Sink Support:

Before you install the Heat Sink Support, please check your Pentium II processor, if you have an Intel boxed processor (Refer to Figure 2-5), you can ignore this section. In Intel boxed processor kit, it will includes it's own Heat Sink Support accessories and install manual, you can Install the Heat Sink Support onto the mainboard by following the Intel processor kit's instructions.

Figure 2-6 shows the OEM type Pentium II processor with active heat sink.

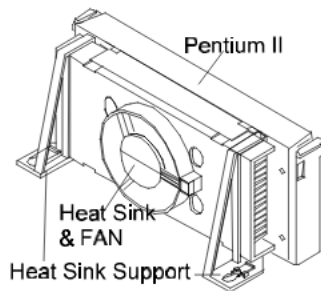

Figure 2-5

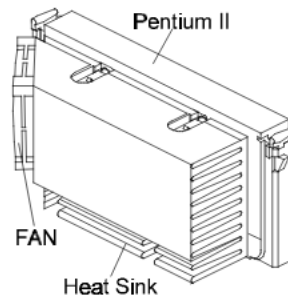

Figure 2-6

1. Finds out the Heat Sink Support (HSS) Mounting Holes on HOT-637 main board. Notice that one hole is larger than the other hole. (Refer to Figure 2-1)

2. There are two plastic pegs on the bottom of Heat Sink Support Base (HSSBASE) bar. Mount the two black plastic pegs onto the mainboard. Notice that one hole and the bar of one peg are larger than the other hole and peg. (Refer to Figure 2-7)

3. Insert the Heat Sink Pins (HSSPIN) through the HSSBASE to secure it to the mainboard. (Refer to Figure 2-7)

4. Insert the Pentium II into the RM firmly (Please refer to "Install Pentium II processor" section), Slide the Heat Sink Top Bar (HSSTOP) on the supports forward to clip onto the HSSBASE through the fins of Heat Sink. (Refer to Figure 2-8)

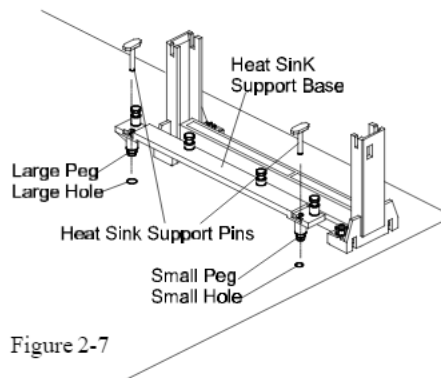

Figure 2-7

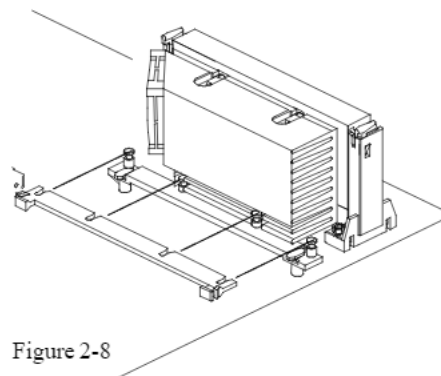

Figure 2-8

Install Pentium II Processor

Push the latches on the processor toward the center of the processor until they click into place.

Hold the processor so that the fan shroud is facing toward the Heat Sink Support Base bar on the mainboard. Slide the processor into the Retention Mechanism. Ensure that the alignment notch in the processor fits over the plug in Slot 1. Push the processor down firmly, with even pressure on both sides of the top, until it is seated.

Push the latches on the processor outward until they click into place in the Retention Mechanism. The latches must be secured for proper electrical connection of the processor. Slide the Heat Sink Top Bar (HSSTOP) on the supports forward to clip onto the HSSBASE through the fins of Heat Sink. (Also refer to "Install Heat Sink Support" section)

Attach the end of the power cable to the three-pin connector on the mainboard or to the power cord of ATX power supply (depend on power cable type of Fan/Heat Sink).

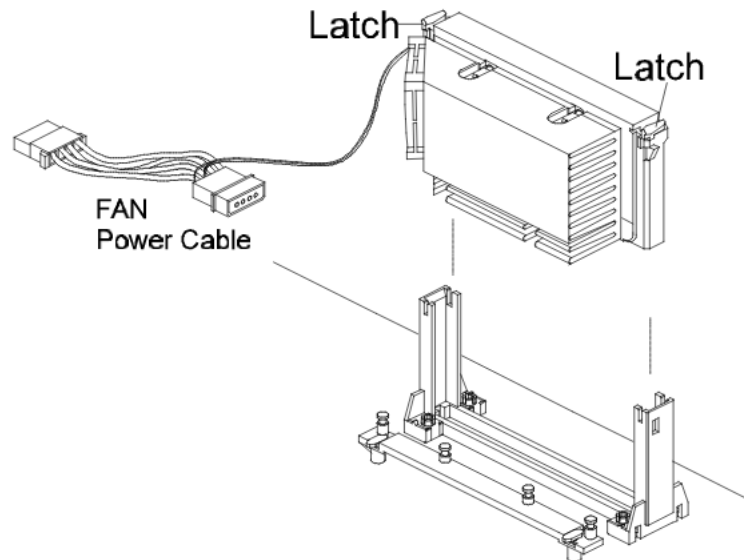

Figure 2-9

Jumpers

Several hardware settings are made through the use of jumper caps to connect jumper pins on the main board. The jumper's pin 1 on main board will be on the top or on the left when holding the main board with the keyboard connector away from yourself.

Jumpers with two pins will be shown a  for Close (On) and  for Open (Off). To connect the pins, simply place a plastic jumper cap over the two pins.

CPU Clock Speed Selection - JP35 and JP37

HOT-637 mainboard features a clock generator to provide adjustable system clock frequency. JP35 is a 8-pin jumpers which determine the system clock frequency 50 MHz to 83 MHz.

HOT-637 mainboard also provides a 8-pin Jumpers JP37 to figure the CPU core clock multiplier. By inserting jumper caps on these jumpers, the user can figure the **Host Bus Clock/ CPU Core Clock** ratio.

Figure 2-10 shows the position of JP35 and JP37 on the mainboard.

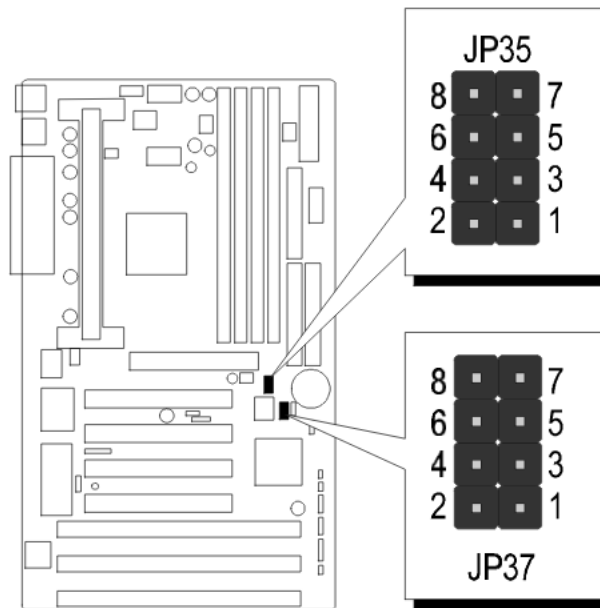

Figure 2-10

CPU Clock Configuration Table shows the Pentium II 233MHz, 266MHz, 300MHz and 333MHz quick setting on the mainboard.

System Clock Table (Table 2-2) shows all of the system bus clocks that the mainboard can offer.

Multiplier Table (Table 2-3) shows all of the multipliers that the mainboard can support.

CPU Configuration Table

Pentium II Processor	System Clock	Multiplier
233 MHz	66 MHz	3.5
266 MHz	66 MHz	4
300 MHz	66 MHz	4.5
333 MHz	66 MHz	5

Table 2-1

System Clock Configuration Table





System Clock	PCI Bus Clock	JP35
50 MHz	25 MHz	
60 MHz	30 MHz	
66 MHz	33 MHz	
75 MHz	37.5 MHz	
83 MHz	41.5 MHz	

Table 2-2

Multiplier Table

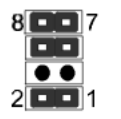
Multiplier	JP37
2	
2.5	
3	
3.5	
4	
4.5	
5	
5.5	

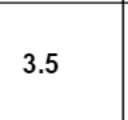
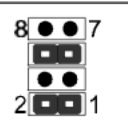
Table 2-3

NOTE: 75 & 83 MHz are for over-clock usage, it is not a recommended general practice.

Clear CMOS - JP19

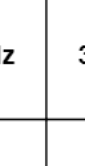
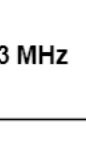
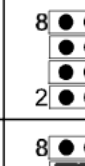
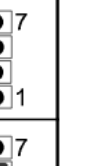
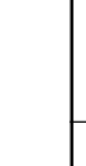
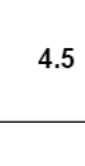
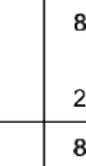
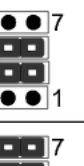

HOT-637 mainboard supports jumper **JP19** for discharging mainboard's CMOS memory.

This jumper can clear the CMOS data stored in the Giga I/O chip. To clear the CMOS data please follow listed steps:

- 1) Turn off the PC,
- 2) Remove the jumper cap from JP19 pin 1-2,
- 3) Insert the jumper cap to JP19 pin 2-3 for a brief while,
- 4) Remove the jumper cap from JP19 pin 2-3,
- 5) Reinsert the jumper cap to JP19 pin 1-2,
- 6) Turn on the PC.

Jumper for Seagate 5V IDE H.D.D - JP32

HOT-637 mainboard support jumpers **JP32** to enhance compatibility with Seagate 5V IDE hard disk drives in the market.

Manufacturer Default	 JP32
When using Seagate 5V IDE hard disk drives	 JP32

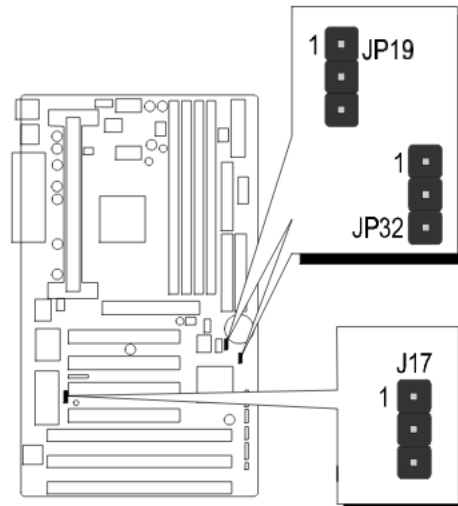

Flash EEPROM Vpp - J17

HOT-637 mainboard supports two types of Flash EEPROM: 5 volt and 12 volt. By setting up jumper JP19, the main board can use both 5V or 12V flash EEPROM with new system BIOS files as they come available.



J17 Pin 2-3 Close for 5V Flash EEPROM



J17 Pin 1-2 Close for 12V Flash EEPROM

Connectors

PIN	Function	PIN	Function
J13 (IDE1)	Primary IDE Connector	J14 (IDE2)	Secondary IDE Connector
J22 (FDD)	Floppy Connector	J20 (COM1)	COM 1 Connector
J19 (PRT)	Parallel Port Connector	J21 (COM2)	COM 2 Connector
J23 (KB)	PS/2 Keyboard Connector	J24 (MS)	PS/2 Mouse Connector
J33, J34	Universal Serial Bus (USB) Connectors	JP28, JP29, J43	12V Cooling Fan Connector
J27	Power LED and Keylock Connector	S1 (PW ON)	Power Soft Switch Connector
JP24	PC Speaker Connector	J32	Hardware Reset Switch Connector
S3	On-board EIDE R/W LED Connector	JP4	Infra-red Communication Port Connector

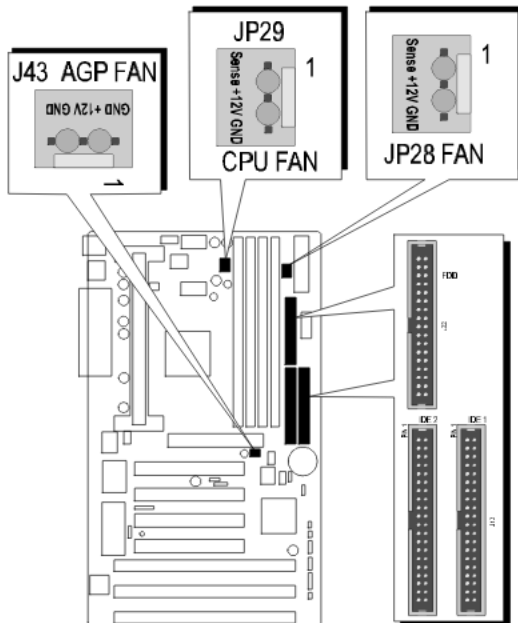

Enhanced IDE and Floppy connectors

The main board shipped with one 40-pin ribbon cable for IDE H.D.D , one 34-pin ribbon cable for F.D.D. Ribbon cables should always be connected with the red stripe on the Pin 1 side of the connector.

12V cooling fan power connectors - JP28, JP29, J43

The main board provides three onboard 12V cooling fan power connectors which provide **maximum 100mAMP current** each for CPU (Fan1), System(Fan 2) and AGP device (Fan 3) cooling fan. Depending on the fan maker, the wiring and plug may be different. The red wire should be connected to +12V and black wire should be connected to ground (GND), and the yellow wire should be connected to Sense signal. The rotate speed of Fan 1 and Fan 2 will be reported on Advanced Chipset Feature Setup of BIOS.

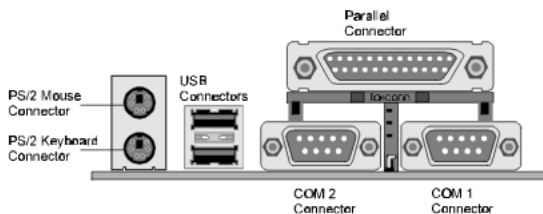

Back Panel Connectors

The back panel provides external access to 6-pin female PS/2 style keyboard and mouse connectors as well as two 9-pin male serial connectors, one 25-pin female parallel connector and two 4-pin female USB connectors which are integrated on the HOT-637 main board.

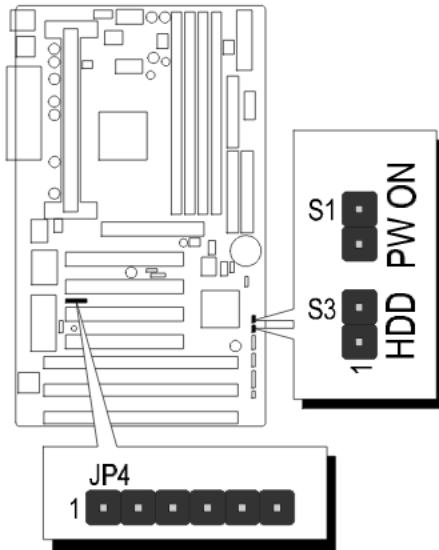

Infrared module connector - JP4

The main board provides a 6-pin infrared connector - IR2 as an optional infrared module for wireless transmitting and receiving.

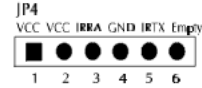

On-board EIDE LED connector - S3

The main board provides a 2-pin EIDE LED connector - S3, make sure connect red wire attached on LED to S3 pin.

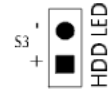

ATX Power Switch Button Connector- S1

When "Soft-off by PWR-BTTN" set to **Delay 4 sec.** on Power management setup of BIOS program. The system power can be controlled by a momentary switch connector. Pushing the switch button less than 4 seconds will switch the system between ON and SUSPEND. Pushing the switch button for more than 4 seconds will turn off the system.

When "Soft-off by PWR-BTTN" set to **Instant-Off** on Power management setup of BIOS program. Pushing the switch button less than 4 seconds will turn the system off directly.

3

MEMORY CONFIGURATION

The HOT-637 mainboard provides four 168-pin DIMM sockets that make it possible to install from 8MB up to 512MB of SDRAM and EDO DRAM. The DIMM socket support 8MB, 16MB, 32MB, 64MB and 128MB 3.3V single- or double-side SDRAM and EDO DIMM.

The four DIMM sockets are arranged in four banks of one socket each, Each bank provides a 64/72-bit wide data path.

HOT-637 provides optional data integrity features including EC (Error Checking) or ECC (Error Checking and Correcting) in the memory array. EC mode provides single and multiple bit error detection. In ECC mode, during reads from the DRAM, the HOT-637 provides error checking and correction of the data.

To support ECC, you must use true (opposed to phantom parity generated by TTL chips) 72-bit parity-type DIMM for all modules.

Install memory in any or all of the banks in any combination as follows:

DIMM Socket	Memory Modules	Module Quantity
DIMM 0	8MB, 16MB, 32MB, 64MB, 128MB 168-pin 3.3V SDRAM or EDO DIMM	x 1
DIMM 1	8MB, 16MB, 32MB, 64MB, 128MB 168-pin 3.3V SDRAM or EDO DIMM	x 1
DIMM 2	8MB, 16MB, 32MB, 64MB, 128MB 168-pin 3.3V SDRAM or EDO DIMM	x 1
DIMM 3	8MB, 16MB, 32MB, 64MB, 128MB 168-pin 3.3V SDRAM or EDO DIMM	x 1

4 FLASH UTILITY

This chapter briefly discusses Award Flash utility in order to guide you through updating your old BIOS. The file name we use to program here is test.bin, and the file name to save old BIOS is 637.OLD. Please note that those file names are not absolute. They are only examples to let you have a more clear understanding of the updating process.

How to Begin

1. Please type "awdf flash" and press the ENTER key to begin the updating process.
2. Once you enter, you will see a main menu displaying:
3. Move the cursor to "File Name to Program: "
4. Type the program name "test.bin", and then press the ENTER key.
5. At the bottom of the menu, you will be requested to answer:

"Do You Want to Save BIOS (Y/N)? "

```
FLASH MEMORY WRITER v5.32B
Copyright (C) 1993, Award Software, Inc.,

For i430TX,ITE8600-2059IH2HC  DATE: 06/20/97
Flash Type - MXIC 28F1000AP /12U

File Name to Program : test.bin

Error Message: Do You Want To Save Bios (Y/N)
```

The following manual is intended to guide you through the process of both "No" and "Yes" cases respectively.

If "No"

If you do not wish to save the old BIOS:

1. Please type "N", and then press the ENTER key.
2. Then you will be requested to answer:

"Are You Sure to Program? "

3. Answer "N" if you do not want to program, and then it will exit.

If "Yes'

To save the old BIOS:

1. Please respond "Y", and then press the ENTER key.
2. Move the cursor to "File Name to Save: "
3. Type file name "631.OLD", and then press the ENTER key. (Your old BIOS will be saved in the file name you create. In this case, the old BIOS is saved in the file name, 631.OLD).
4. Then you will be requested to answer:
'Are You Sure to Program (Y/N)? "

```
FLASH MEMORY WRITER v5.32B
Copyright (C) 1993, Award Software, Inc.,

For i430TX,ITE8600-2A59IH2HC  DATE: 06/20/97
Flash Type - MXIC 28F1000AP /12U

File Name to Program : test.bin
File Name to Save : 631.old

Error Message: Are you sure to program (y/n)
```

5. Type "Y" to begin programming, and press the ENTER key.
6. When the programming is finished, the showing message will appear:
7. Once you see the showing message "Power Off or Reset System", please restart your system.
8. When you power on the computer again, you will find your old BIOS has already been successfully updated.

To view a complete usage of FLASH utility, please type "awdf flash /?" and press the ENTER key.

Notes About Award Flash Utility

Please note that Award Flash Utility cannot run under **EMM386** or **QEMM**. Thus, when executing the command "awdf flash", an error message will appear:

"Error Message: Fail — Due to EMM386 or QEMM !"

5 BIOS SETUP

HOT-637 BIOS ROM has a built-in Setup program that allows users to modify the basic system configuration. This information is stored in battery-backed RAM so that it retains the Setup information when ever the power is turned off.

Entering Setup

Power on the computer and press immediately will allow you to enter Setup. The other way to enter Setup is to power on the computer, when the below message appear briefly at the bottom of the screen during the POST (Power On Self Test), press key or simultaneously press <Ctrl>, <Alt>, and <Esc> keys.

TO ENTER SETUP BEFORE BOOT PRESS CTRL-ALT-ESC OR DEL KEY

If the message disappears before you respond and you still wish to enter Setup, restart the system to try again by turning it OFF the ON or pressing the "RESET" button on the system case. You may also restart by simultaneously press <Ctrl>, <Alt>, and <Delete> keys. If you do not press the keys at the correct time and the system does not boot, an error message will be displayed and you will again be asked to,

PRESS F1 TO CONTINUE, CTRL-ALT-ESC OR DEL TO ENTER SETUP

The Main Menu

ROM PCI/ISA BIOS (2869JH2B) CMOS SETUP UTILITY AWARD SOFTWARE, INC.	
STANDARD CMOS SETUP	INTEGRATED PERIPHERALS
BIOS FEATURES SETUP	SUPERVISOR PASSWORD
CHIPSET FEATURES SETUP	USER PASSWORD
POWER MANAGEMENT SETUP	IDE HDD AUTO DETECTION
PnP/PCI CONFIGURATION	SAVE & EXIT SETUP
LOAD BIOS DEFAULTS	EXIT WITHOUT SAVING
LOAD SETUP DEFAULTS	
Esc : Quit	↑ ↓ + + : Select Item
F10 : Save & Exit Setup	(Shift)F2 : Change Color

Standard CMOS setup

This setup page includes all items in a standard compatible BIOS.

BIOS features setup

This setup page includes all items of Award special enhanced features.

Chipset features setup

This setup page includes all items of chipset features.

Power Management Setup

This setup page includes all items of Power Management features.

PnP/PCI Configuration setup

This item specifies the value (in units of PCI bus blocks) of the latency timer for the PCI bus master and the IRQ level for PCI device. Power-on with BIOS defaults

Load BIOS Defaults

BIOS defaults loads the values required by the System for the maximum performance. However, you can change the parameter through each Setup Menu.

Load Setup Defaults

Setup defaults loads the values required by the system for the O.K. performance. However, you can change the parameter through each Setup Menu.

Integrated Peripherals

This setup page includes all items of peripheral features.

IDE HDD auto detection

Automatically configure IDE hard disk drive parameters.

Supervisor Password

Change, set, or disable supervisor password. It allows you to limit access to the system and Setup, or just to Setup.

User Password

Change, set, or disable user password. It allows you to limit access to the system and Setup, or just to Setup.

Save & Exit setup

Save CMOS value change to CMOS and exit setup

Exit without saving

Abandon all CMOS value changes and exit setup.

Standard CMOS Setup

```
ROM PCI/ISA BIOS (2A69JH2B)
STANDARD CMOS SETUP
AWARD SOFTWARE, INC.

Date (mm:dd:yy) : Sat, Sep 13 1997
Time (hh:mm:ss) : 11 : 27 : 15

HARD DISKS      TYPE      SIZE  CYLS  HEAD  PRECOMP  LANDZ  SECTOR  MODE
-----
Primary Master  : Auto      0      0    0      0      0      0  AUTO
Primary Slave   : Auto      0      0    0      0      0      0  AUTO
Secondary Master : Auto      0      0    0      0      0      0  AUTO
Secondary Slave  : Auto      0      0    0      0      0      0  AUTO

Drive A : 1.44M, 3.5 in.
Drive B : None

Video : EGA/UGA
Halt On : All Errors

Base Memory : 0K
Extended Memory : 0K
Other Memory : 512K
-----
Total Memory : 512K

ESC : Quit      ↑ ↓ → ← : Select Item      PU/PD/+/- : Modify
F1  : Help      (Shift)F2 : Change Color
```

Date

The date format is <day>, <month> <date> <year>. Press <F3> to show the calendar.

Time

The time format is <hour> <minute> <second>. The time is calculated base on the 24-hour military-time clock. For example, 5 p.m. is 17:00:00.

Hard Disks Type

This item identify the types of hard disk drives that has been installed in the computer. There are 46 predefined types and a user definable type.

Press PgUp or PgDn to select a numbered hard disk type or type the number and press <Enter>. Note that the specifications of your drive must match with the drive table. The hard disk will not work properly if you enter improper information for this item. If your hard disk drive type is not matched or listed, you can use Type User to define your own drive type manually.

If you select Type User, related information is asked to be entered to the following items. Enter the information directly from the keyboard and press <Enter>. Those information should be provided in the documentation from your hard disk vendor or the system manufacturer.

The user may also set those items to AUTO to auto configure hard disk drives parameter when system power-on.

If a hard disk drive has not been installed select NONE and press <Enter>.

Drive A type/Drive B type

This item specifies the types of floppy disk drive A or drive B that has been installed in the system.

Video

This item selects the type of adapter used for the primary system monitor that must match your video display card and monitor. Although secondary monitors are supported, you do not have to select the type in Setup.

Error halt

This item determines if the system will stop, when an error is detected during power up.

Memory

This item is display-only. It is automatically detected by POST (Power On Self Test) of the BIOS.

Base Memory

The POST of the BIOS will determine the amount of base (or conventional) memory installed in the system. The value of the base memory is typically 512K for systems with 512K memory installed on the mainboard, or 640K for systems with 640K or more memory installed on the mainboard.

Extended Memory

The BIOS determines how much extended memory is present during the POST. This is the amount of memory located above 1MB in the CPU's memory address map.

BIOS Features Setup

ROM PCI/ISA BIOS (2A69JH2D) BIOS FEATURES SETUP AWARD SOFTWARE, INC.			
Virus Warning	: Disabled	Video BIOS Shadow	: Enabled
CPU Internal Cache	: Enabled	C0000-CBFFF Shadow	: Disabled
External Cache	: Enabled	CC000-CFFFF Shadow	: Disabled
Quick Power On Self Test	: Enabled	D0000-D3FFF Shadow	: Disabled
Boot Sequence	: A,C,SCSI	D4000-D7FFF Shadow	: Disabled
Swap Floppy Drive	: Disabled	D8000-DBFFF Shadow	: Disabled
Boot Up Floppy Seek	: Enabled	DC000-DFFFF Shadow	: Disabled
Boot Up NumLock Status	: On		
Boot Up System Speed	: High		
Gate A20 Option	: Fast		
Typeomatic Rate Setting	: Disabled		
Typeomatic Rate (Chars/Sec)	: 6		
Typeomatic Delay (Msec)	: 250		
Security Option	: Setup		
PCI/VCA Palette Snoop	: Disabled		
OS Select For DRAM > 64MB	: Non-US2		
		ESC : Quit	F4++ : Select Item
		F1 : Help	PU/PD/+/- : Modify
		F5 : Old Values (Shift)	F2 : Color
		F6 : Load BIOS Defaults	
		F7 : Load Setup Defaults	

Virus Warning

When this item is enabled, the Award BIOS will monitor the boot sector and partition table of the hard disk drive for any attempt at modification. If an attempt is made, the BIOS will halt the system and the following error message will appear. Afterwards, if necessary, you will be able to run an anti-virus program to locate and remove the problem before any damage is done.

!WARNING!
Disk boot sector is to be modified
Type "Y" to accept write or "N" to abort write
Award Software, Inc.

CPU Internal Cache

This item enables CPU internal cache to speed up memory access.

External Cache

This item enables CPUsecondary cache to speed up memory access.

Quick Power On Self Test

This item speeds up Power On Self Test (POST) after you power on the computer. If it is set to Enabled, BIOS will shorten or skip some check items during POST.

Boot Sequence

This item determines which drive computer searches first for the disk operating system. Default setting is A, C, SCSI.

BIOS also support system boot from CD-ROM drive or SCSI hard disk drive.

Swap Floppy Drive

When this item enables, the BIOS will swap floppy drive assignments so that Drive A: will function as Drive B: and Drive B: as Drive A:.

Boot Up Floppy Seek

During POST, BIOS will determine if the floppy disk drive installed is 40 or 80 tracks.

Boot Up NumLock Status

When this option enables, BIOS turns on *Num Lock* when system is powered on.

Boot Up System Speed

This option sets the speed of the CPU at system boot time. The settings are *High* or *Low*.

Gate A20 Option

This entry allows you to select how the gate A20 is handled. The gate A20 is a device used to address memory above 1 MByte. Initially, the gate A20 was handled via a pin on the keyboard. Today, while keyboards still provide this support, it is more common, and much faster, set to Fast for the system chipset to provide support for gate A20.

Typematic Rate Setting

This determines if the typematic rate is to be used. When disabled, continually holding down a key on your keyboard will generate only one instance. In other words, the BIOS will only report that the key is down. When the typematic rate is enabled, the BIOS will report as before, but it will then wait a moment, and, if the key is still down, it will begin the report that the key has been depressed repeatedly. For example, you would use such a feature to accelerate cursor movements with the arrow keys.

Typematic Rate (Chars/Sec)

When the typematic rate is enabled, this selection allows you select the rate at which the keys are accelerated.

Typematic Delay (Msec)

When the typematic rate is enabled, this selection allows you to select the delay between when the key was first depressed and when the acceleration begins

Security Option

This item allows you to limit access to the System and Setup, or just to Setup.

When *System* is selected, the System will not boot and access to Setup will be denied if the correct password is not entered at the prompt.

When *Setup* is selected, the System will boot, but access to Setup will be denied if the correct password is not entered at the prompt.

PCI VGA Palette Snoop

This item must be set to enabled if there is a MPEG ISA card installed in the system, and disabled if there is no MPEG ISA card installed in the system.

OS Select For DRAM > 64MB

This item allows you to access the memory that over 64 MB in OS/2.

Video BIOS Shadow

Determines whether video BIOS will be copied to RAM. However, it is optional depending on chipset design. Video Shadow will increase the video speed.

C8000-CBFFF Shadow/DC000-DFFFF Shadow

These categories determine whether option ROMs will be copied to RAM. An example of such option ROM would be support of on-board SCSI.

Chipset Features Setup

ROM PCI/ISA BIOS (2A69JH2B)	
CHIPSET FEATURES SETUP	
AWARD SOFTWARE, INC.	
Auto Configuration	: Enabled
DRAM Speed Selection	: 60ns
MA Wait State	: Slow
EDO RAS# To CAS# Delay	: 3
EDO RAS# Precharge Time	: 4
EDO DRAM Read Burst	: x222
EDO DRAM Write Burst	: x333
DRAM Data Integrity Mode	: Non-ECC
CPU-To-PCI IDE Posting	: Enabled
System BIOS Cacheable	: Disabled
Video BIOS Cacheable	: Enabled
Video RAM Cacheable	: Enabled
8 Bit I/O Recovery Time	: 3
16 Bit I/O Recovery Time	: 2
Memory Hole At 15M-16M	: Disabled
Passive Release	: Enabled
Delayed Transaction	: Enabled
AGP Aperture Size (MB)	: 64
SDRAM RAS-to-CAS Delay	: Slow
SDRAM RAS Precharge Time	: Slow
SDRAM CAS latency Time	: 3
Auto Detect DIMM/PCI Clk	: Disabled
Spread Spectrum Modulated	: Disabled
Current System Temp.	: xxC/xxF
Current CPUFAN1 Speed	: xxxRPM
Current CPUFAN2 Speed	: xxxRPM
IN0(V)	: 2.8xV
IN2(V)	: 3.3xV
IN4(V)	: 12.xV
IN6(V)	: -5.xV
IN1(V)	: 2.8xV
IN3(V)	: 5.xV
IN5(V)	: -12.xV
ESC	: Quit
F1	: Help
F5	: Old Values
F6	: Load BIOS Defaults
F7	: Load Setup Defaults
↑↓	: Select Item
PU/PD/+/-	: Modify
(Shift)F2	: Color

Auto Configuration

The default setting of the optimal timings for items 3 through 7 for 60ns EDO DRAM modules.

DRAM Speed Selection

This item set the EDO DRAM Read/Write timings that the system uses. When item of "Auto Configuration" is disabled, this item will not show up.

MA Additional Wait State

When enabled, one additional wait state is inserted before the assertion of the first memory address line MA and CAS/RAS assertion during DRAM read or write leadoff cycles.

EDO RAS To CAS# Delay

When EDO DRAM is refreshed, both rows and columns are address separately. This setup item allows you to determine the timing of the transition from Row Address Strobe (RAS) to Column Address Strobe (CAS). The options are **3** and **2**.

EDO RAS# Precharge Time

DRAM must continually be refreshed or it will lose its data. Normally, DRAM is refreshed entirely as the result of a single request. This option allows you to determine the number of CPU clocks allocated for Row Address Strobe to accumulate its charge before the DRAM is refreshed. If insufficient time is allowed, refresh may be incomplete and data lost.

This item sets the DRAM RAS Precharge Timing. The options are **4** and **3** CLKs.

EDO DRAM Read Burst

This item set the EDO DRAM Read Burst Timing. The timing used depends on the type of DRAM (EDO burst mode or standard fast page mode) on a per-bank basis. The options are **222** and **333**.

EDO DRAM Write Burst

This item set the EDO DRAM Write Burst timing for accessing DRAM. The options are **222** and **333**.

DRAM Data Integrity Mode

This item allows the user to set DRAM data integrity mode to *Non-ECC* or *ECC*. Non-ECC has byte-wide write capability but no provision for protecting data integrity in the DRAM array. ECC allows a detection of single-bit and multiple-bit errors and recovery of single-bit errors.

CPU-To-PCI IDE Posting

When disabled, the CPU to PCI IDE posting cycles are treated as normal I/O write transactions. When enabled will have the I/O write cycles posted.

System BIOS Cacheable

This item allows the user to set whether the system BIOS F000~FFFF areas are cacheable or non-cacheable.

Video BIOS Cacheable

This item allows the user to set whether the video BIOS C000~C7FF areas are cacheable or non-cacheable.

Video RAM Cacheable

This is a new cache technology for the video memory of the processor. It can greatly improve the display speed by caching the display data. You must leave this on the default setting of *Disabled* if your display card cannot support this feature or else your system may not boot.

8 Bit I/O Recovery Time

The recovery time is the length of time, measured in CPU clocks, which the system will delay after the completion of an input/output request. This delay takes place because the CPU is operating so much after than the input/output bus that the CPU must be delayed to allow for the completion of the I/O.

This item allows you to determine the recovery time allowed for 8 bit I/O. Choices are from NA, 1 to 8 CPU clocks.

16-Bit I/O Recovery Time

This item allows you to determine the recovery time allowed for 16 bit I/O. Choices are from NA, 1 to 4 CPU clocks.

Memory Hole At 15M-16M

In order to improve performance, certain space in memory can be reserved for ISA cards. This memory must be mapped into the memory space below 16 MB.

Passive Release

When enabled, the chipset provides a programmable passive release mechanism to meet the required ISA master latencies.

Delayed Transaction

Since the 2.1 revision of the PCI specification requires much tighter controls on target and master latency, PCI cycles to or from ISA typically take longer. When enabled, the chipset provides a programmable delayed completion mechanism to meet the required target latencies.

AGP Aperture Size (MB)

This item allows the user to set memory-mapped, graphics data structures can reside in Graphics Aperture.

SDRAM RAS-to-CAS Delay

When SDRAM is refreshed, both rows and columns are address separately. This setup item allows you to determine the timing of the transition from Row Address Strobe (RAS) to Column Address Strobe (CAS). The options are *Slow* for 3 and *Fast* for 2 CLKs.

SDRAM RAS Precharge Time

SDRAM must continually be refreshed or it will lose its data. Normally, DRAM is refreshed entirely as the result of a single request. This option allows you to determine the number of CPU clocks allocated for Row Address Strobe to accumulate its charge before the DRAM is refreshed. If insufficient time is allowed, refresh may be incomplete and data lost. The options are *Slow* for 3 and *Fast* for 2 CLKs.

SDRAM CAS Latency Time

This item defines the CAS Latency timing parameter of the SDRAM expressed in 66MHz clocks. The options are 2 and 3 CLKs.

Auto Detect DIMM/PCI Clock

Enabling this item allow system auto detect and close clock signal to empty DIMM/PCI slot to reduce EMI.

Spread Spectrum Modulated

This item allows the user to enable Spread Spectrum Modulated to reduce the EMI.

Current System Temperature (available on HOT-637P only)

Since the mainboard support System temperature monitoring and overheat alert. This item indicate the current main board temperature.

Current CPUFAN1/2 Speed(available on HOT-637P only)

The mainboard can detect two fans rotation speed for CPU cooler and system. CPUFAN1 indicate the CPU cooling fan's rotation speed which inserting on JP28 and CPUFAN2 indicate cooling fans rotation speed which inserting on JP29.

IN0(V) ~ IN6(V) (available on HOT-637P only)

The mainboard support CPU and mainboard voltages monitoring. The onboard hardware monitor is able to detect the voltages output of the voltage regulators and power supply.

Power Management Setup

ROM PCI/ISA BIOS (2A69JH2B) POWER MANAGEMENT SETUP AWARD SOFTWARE, INC.		
Power Management	: Disable	** Reload Global Timer Events **
PM Control by APM	: Yes	IRQ[3-7,9-15],NMI : Enabled
Video Off Method	: U/H SYNC+Blank	Primary IDE 0 : Disabled
Video Off After	: Standby	Primary IDE 1 : Disabled
MODEM Use IRQ	: 3	Secondary IDE 0 : Disabled
		Secondary IDE 1 : Disabled
Doze Mode	: Disable	Floppy Disk : Disabled
Standby Mode	: Disable	Serial Port : Enabled
Suspend Mode	: Disable	Parallel Port : Disabled
HDD Power Down	: Disable	
Throttle Duty Cycle	: 62.5%	
UGA Active Monitor	: Enabled	
Soft-Off by PWR-BTTON	: Instant-Off	
CPUFAN Off In Suspend	: Enabled	
Resume by Ring	: Enabled	
Resume by Alarm	: Disabled	
		ESC : Quit F10 : Select Item
		F1 : Help PU/PD/+/- : Modify
		F5 : Old Values (Shift)F2 : Color
		F6 : Load BIOS Defaults
		F7 : Load Setup Defaults
IRQ 8 Break Suspend	: Disabled	

Power Management

This item determines the options of the power management function. *Max Saving* puts the system into power saving mode after a brief period of system inactivity; *Min Saving* is the same as *Max Saving* except the time of the system inactivity period is longer; *Disabled* disables the power saving feature; *User Defined* allows you to set power saving options according to your preference.

PM Control by APM

If this item set to *No*, system BIOS will be ignored and APM calls the power to manage the system.

If this item setup to *Yes*, system BIOS will wait for APM's prompt before it enter any PM mode e.g. *DOZE*, *STANDBY* or *SUSPEND*.

Video Off Method

This item define the video off features - *V/H SYNC+Blank*, *DPMS*, and *Blank Only*. The first option, which is the default setting, blanks the screen and turns off vertical and horizontal scanning; *DPMS* allows the BIOS to control the video display card if it supports the *DPMS* feature; *Blank Screen* only blanks the screen.

Video Off After

This item define when to activate the video off feature for monitor power management. The settings are *N/A*, *Doze*, *Standby* and *Suspend*.

MODEM Use IRQ

This item determines the IRQ in which the MODEM can use.
The choice: 1, 3, 4, 5, 7, 9, 10, 11, *N/A*.

Doze Mode

When enabled and after the set time of system inactivity, the CPU clock will run at slower speed while all other devices still operate at full speed.

Standby Mode

When enabled and after the set time of system inactivity, the fixed disk drive and the video would be shut off while all other devices still operate at full speed.

Suspend Mode

When enabled and after the set time of system inactivity, all devices except the CPU will be shut off.

HDD Power Down

This item defines the continuous HDD idle time before the HDD enters power saving mode (motor off). The options are from 1 min to 15 min and *Disabled*.

Throttle Duty Cycle

This item determines the duty cycle for the clock control thermal throttling mode. The duty cycle indicates the percentage of time while in the thermal throttle mode. The settings between 12.5% and 87.5%.

VGA Active Monitor

If this item is set to Enabled, the VGA activity event will be monitored to reload global timer.

Soft-Off by PWR-BTTN

(This feature is available for ATX power only)

The setting of **Instant-Off** allows the ATX switch to function as a normal system power off button when pressed for less than 4 seconds. The setting of **Delay 4 Sec.** allows the button to have a dual function where to press the button for less than 4 seconds will place the system in suspend mode, and pressing the button for more than 4 seconds will shut place the system off.

Resume by Ring

This item determine the system will resume by activating of modem ring.

Resume by Alarm

(This feature is available for ATX power only)

This item determine the system will resume by activity of R.T.C. If enabled this feature and enter resume date and time. When date and time expire, system will power-on itself from power off.

IRQ 8 Break Suspend

You can turn On or Off monitoring of IRQ8 (the Real Time Clock) so it does not awaken the system from Suspend mode.

**** Reload Global Timer Events ****

If any of these items is set to Disabled, that system activity event will not be monitored to reload global timer.

If these items is set to Enabled, that system activity event will be monitored to reload global timer.

These items include IRQ[3-7, 9-15], NMI, Primary IDE0/1, Secondary IDE 0/1, Floppy Disk, Serial Port and Parallel Port.

PCI Configuration Setup

ROM PCI/ISA BIOS (2A69JH2B) PNP/PCI CONFIGURATION AWARD SOFTWARE, INC.	
PNP OS Installed : No	PCI IDE IRQ Map To : PCI-AUTO
Resources Controlled By : Manual	Primary IDE INT# : A
Reset Configuration Data : Disabled	Secondary IDE INT# : B
IRQ-3 assigned to : Legacy ISA	Assign IRQ For USB : Disabled
IRQ-4 assigned to : Legacy ISA	MS IRQ Routing Table : Disabled
IRQ-5 assigned to : PCI/ISA PnP	PCI Latency Timer(CLK): 64
IRQ-7 assigned to : PCI/ISA PnP	
IRQ-9 assigned to : PCI/ISA PnP	
IRQ-10 assigned to : PCI/ISA PnP	
IRQ-11 assigned to : PCI/ISA PnP	
IRQ-12 assigned to : PCI/ISA PnP	
IRQ-14 assigned to : PCI/ISA PnP	
IRQ-15 assigned to : PCI/ISA PnP	
DMA-0 assigned to : PCI/ISA PnP	
DMA-1 assigned to : PCI/ISA PnP	ESC : Quit F1++ : Select Item
DMA-3 assigned to : PCI/ISA PnP	F1 : Help PU/PD/+/- : Modify
DMA-5 assigned to : PCI/ISA PnP	F5 : Old Values (Shift)F2 : Color
DMA-6 assigned to : PCI/ISA PnP	F6 : Load BIOS Defaults
DMA-7 assigned to : PCI/ISA PnP	F7 : Load Setup Defaults

PNP OS Installed

When this item is set to Yes, it will allow the PnP OS(Windows 95) control the system resources except PCI devices and PnP boot devices.
Default setting is *No*.

Resources Controlled By

The Award Plug and Play BIOS has the capability to automatically configure all of the boot and Plug and Play compatible devices. However, this capability means absolutely nothing unless you are using a Plug and Play operating system as Windows 95.

Reset Configuration Data

This item allows you to determine whether to reset the configuration data or not.

IRQ 3/4/5/7/9/10/11/12/14/15, assigned to

These items allow you to determine the IRQ assigned to the ISA bus and is not available for PCI slot.

Choices are *Legacy ISA* and *PCI/ISA PnP*.

DMA 0/1/3/5/6/7 assigned to

These items allow you to determine the DMA assigned to the ISA bus and is not available for PCI slot.

Choices are *Legacy ISA* and *PCI/ISA PnP*.

PCI IRQ Activated by

This item sets the method by which the PCI bus recognize that an IRQ service is being requested by a device. You should never change the default configuration unless advised otherwise by your System's manufacturer. Choices are *Level*(default) and *Edge*.

PCI IDE IRQ Map to

This item allows you to configure your system to the type of IDE disk controller in use. By default, Setup assumes that your controller is an ISA device rather than a PCI controller.

If you have equipped your system with a PCI controller, changing this allows you to specify which slot has the controller and which PCI interrupt (A, B, C or D) is associated with the connected hard drives.

Remember that this setting refers to the hard disk drive itself, rather than individual partitions. Since each IDE controller supports two separate hard disk drives, you can select the INT# for each. Again, you will note that the primary has a lower interrupt than the secondary as described in "*Slot x Using INT#*" above.

Selecting "*PCI Auto*" allows the system to automatically determine how your IDE disk system is configured.

Assign IRQ for USB

This item allows the user to assign IRQ to on-board USB controller or not.

Since on-board controller is enabled always, if none of IRQ is assigned to it, there will be a question mark report on system device under windows 95.

MS IRQ Routing Table

This item allows the user to set BIOS IRQ Routing Table Enabled or Disabled.

PCI Latency Timer

The number of clocks programmed in the PCI Latency Timer represents the guaranteed time slice allotted to the 440LX, after which it must complete the current data transfer phase and surrender the bus as soon as its bus grant is removed.

The PCI Latency Timer is used to guarantee to the PCI agents a minimum amount of the system resource.

The default setting is 64 PCI clocks.

Integrated Peripherals

ROM PCI/ISA BIOS (2A69JH2B) INTEGRATED PERIPHERALS AWARD SOFTWARE, INC.	
IDE HDD Block Mode : Enabled	Parallel Port Mode : SPP
IDE Primary Master PIO : Auto	
IDE Primary Slave PIO : Auto	
IDE Secondary Master PIO : Auto	
IDE Secondary Slave PIO : Auto	
IDE Primary Master UDMA : Auto	
IDE Primary Slave UDMA : Auto	
IDE Secondary Master UDMA : Auto	
IDE Secondary Slave UDMA : Auto	
On-Chip Primary PCI IDE : Enabled	
On-Chip Secondary PCI IDE : Enabled	
USB Keyboard Support : Disabled	
KBC input clock : 0 MHz	
Onboard FDC Controller : Enabled	
Onboard Serial Port 1 : Auto	ESC : Quit F10+ : Select Item
Onboard Serial Port 2 : Auto	F1 : Help PU/PD/+/- : Modify
UR2 Mode : Standard	F5 : Old Values (Shift)F2 : Color
Onboard Parallel Port : 378/IRQ7	F6 : Load BIOS Defaults
	F7 : Load Setup Defaults

IDE HDD Block Mode

This item is used to set IDE HDD Block Mode. If your IDE Hard Disk supports block mode, then you can enable this function to speed up the HDD access time. If not, please disable this function to avoid HDD access error.

IDE Primary Master PIO

In this items, there are five modes defined in manual mode and one automatic mode.

There are *0*, *1*, *2*, *3*, *4*, and *AUTO* is the default settings for on board Primary Master PIO timing.

IDE Primary Slave PIO

In this items, there are five modes defined in manual mode and one automatic mode.

There are *0*, *1*, *2*, *3*, *4*, and *AUTO* is the default settings for on board Primary Slave PIO timing.

IDE Secondary Master PIO

In this items, there are five modes defined in manual mode and one automatic mode.

There are *0*, *1*, *2*, *3*, *4*, and *AUTO* is the default settings for on board Secondary Master PIO timing.

IDE Secondary Slave PIO

In this items, there are five modes defined in manual mode and one automatic mode.

There are *0*, *1*, *2*, *3*, *4*, and *AUTO* is the default settings for on board Secondary Slave PIO timing.

IDE Primary Master UDMA

On this mainboard, Intel 430LX PCIset improves IDE transfer rate using Bus Master UltraDMA/33 IDE which can handle data transfer up to 33MB/sec. The options are *Disabled, Enabled and Auto*, *Auto* is the default settings for on board Primary Master UltraDMA33.

Note : Your hard drive must also support UDMA for this feature to work.

IDE Primary Slave UDMA

On this mainboard, Intel 430LX PCIset improves IDE transfer rate using Bus Master UltraDMA/33 IDE which can handle data transfer up to 33MB/sec. The options are *Disabled, Enabled and Auto*, *Auto* is the default settings for on board Primary Slave UltraDMA33.

Note : Your hard drive must also support UDMA for this feature to work.

IDE Secondary Master UDMA

On this mainboard, Intel 430LX PCIset improves IDE transfer rate using Bus Master UltraDMA/33 IDE which can handle data transfer up to 33MB/sec. The options are *Disabled, Enabled and Auto*, *Auto* is the default settings for on board Secondary Master UltraDMA33.

Note : Your hard drive must also support UDMA for this feature to work.

IDE Secondary Slave UDMA

On this mainboard, Intel 430LX PCIset improves IDE transfer rate using Bus Master UltraDMA/33 IDE which can handle data transfer up to 33MB/sec. The options are *Disabled, Enabled and Auto*, *Auto* is the default settings for on board Secondary Slave UltraDMA33.

Note : Your hard drive must also support UDMA for this feature to work.

On-Chip Primary PCI IDE

As stated above, your system includes two built-in IDE controllers, both of which operate on the PCI bus. This setup item allows you either to enable or disable the primary controller. You might choose to disable the controller if you were to add a higher performance or specialized controller.

On-Chip Secondary PCI IDE

As above for the Primary controller, this setup item you either to enable or disable the secondary controller. You might choose to disable the controller if you were to add a higher performance or specialized controller

USB Keyboard Support

This item is used to defined USB Keyboard is *Enabled* or *Disabled*.

Keyboard Input Clock

This item to set the input clock to onboard keyboard controller. The options are *8MHz* and *12MHz*.

Onboard FDC Control

This item specifies onboard floppy disk drive controller. This setting allows you to connect your floppy disk drives to the onboard floppy connector. Choose the "*Disabled*" settings if you have a separate control card.

Onboard Serial 1

This item is used to define onboard serial port 1 to *3F8/IRQ4*, *2F8/IRQ3*, *3E8/IRQ4*, *2E8/IRQ3*, *Auto* or *Disabled*.

Onboard Serial 2

This item is used to define onboard serial port 2 to *3F8/IRQ4*, *2F8/IRQ3*, *3E8/IRQ4*, *2E8/IRQ3*, *Auto* or *Disabled*.

UR2 Mode

The main board support IrDA(HPSIR) and Amplitudes Shift Keyed IR(ASKIR) infrared through COM 2 port. This item specifies onboard Infra Red mode to *IrDA 1.0*, *ASKIR*, *MIR 0.57M*, *MIR 1.15M*, *FIR* or *Standard (Disabled)*.

Note : FIR is not available currently.

IR Duplex Mode

This item specifies onboard infrared transfer mode to *full-duplex* or *half-duplex*. This item will not show up when IrDA, ASKIR, or MIR UR2 modes are selected.

Onboard Parallel Port

This item specifies onboard parallel port address to *378H*, *278H*, *3BCH* or *Disabled*.

Parallel Port Mode

This item specifies onboard parallel port mode. The options are *SPP* (Standard Parallel Port), *EPP*(Enhanced Parallel Port), *ECP* (Extended Capabilities Port), and *EPP+ECP*.

ECP Mode Use DMA

This item specifies *DMA* (Direct Memory Access) channel when ECP device is in use. The options are *DMA 1* and *DMA 3*. This item will not show up when SPP and EPP printer mode is selected.

Password Setting

This section describes the two access modes that can be set using the options found on the Supervisor Password and User Password.

ROM PCI/ISA BIOS (2A59GH2B) CMOS SETUP UTILITY AWARD SOFTWARE, INC.	
STANDARD CMOS SETUP	INTEGRATED PERIPHERALS
BIOS FEATURES SETUP	IDE HDD AUTO DETECTION
CHIPSET FEATURES SETUP	SUPERVISOR PASSWORD
POWER MANAGEMENT SETUP	USER PASSWORD
PNP/PCI CONFIGURATION	SAVE & EXIT SETUP
LOAD BIOS DEFAULTS	Enter Password: <input type="text"/> UT SAVING
LOAD SETUP DEFAULTS	
Esc : Quit	↑ ↓ → ← : Select Item
F10 : Save & Exit Setup	(Shift)F2 : Change Color
Change/Set/Disable Password	

Supervisor Password and User Password

The options on the Password screen menu make it possible to restrict access to the Setup program by enabling you to set passwords for two different access modes: Supervisor mode and User mode.

In general, Supervisor mode has full access to the Setup options, whereas User mode has restricted access to the options. By setting separate Supervisor and User password, a system supervisor can limit who can change critical Setup values.

Enter Password

Type the password, up to eight characters, and press <Enter>. The password typed now will clear any previously entered password from CMOS memory. You will be asked to confirm the password. Type the password again and press <Enter>. You may also press <Esc> to abort the selection and not enter a password.

To disable password, just press <Enter> when you are prompted to enter password. A message will confirm the password being disabled. Once the password is disabled, the system will boot and you can enter Setup freely.

Password Disable

If you select System at Security Option of BIOS Features Setup Menu, you will be prompted for the password every time the system is rebooted or any time you try to enter Setup. If you select Setup at Security Option of BIOS Features Setup Menu, you will be prompted only when you try to enter Setup.

Warning : Retain a record of your password in a safe place. If you forget the password, the only way to access the system is to clear CMOS memory, please refer to page 14 "Clear CMOS".